



mattel®
COMPRESSED AIR SINCE 1919

GAS **COMPRESSORS**

Rotary vane technology



GAS COMPRESSORS

Rotary vane technology

THE PRESSURE IS ON

In 1958, Ing. **Enea Mattei SpA** leveraged its 39 years of reciprocating compressor manufacturing expertise to revolutionise how air was compressed.

Over half-a-century later, **MATTEI** continues to turn the pressure on in gas compressor applications around the globe.

From bare compressors to packaged systems we leverage the advantages found only in our proprietary rotary vane technology to boost your bottom line. Turn to **MATTEI** for superior reliability, durability, efficiency, and ease of maintenance, all in a compact design ideal

for localised packaging and many gas compressor applications.

Quality as an integral part of all company functions and constant improvement to all production processes guarantees the maximum level of reliability and satisfaction. This, in brief, is the value and the meaning of **Mattei's** operational philosophy. A way of approaching the market and customers that makes Mattei an absolute point of reference in the compressed gas sector.

Since 1994, **Mattei** has been operating with a Quality System certified by the DNV Institute under UNI EN ISO 9001 regulations.

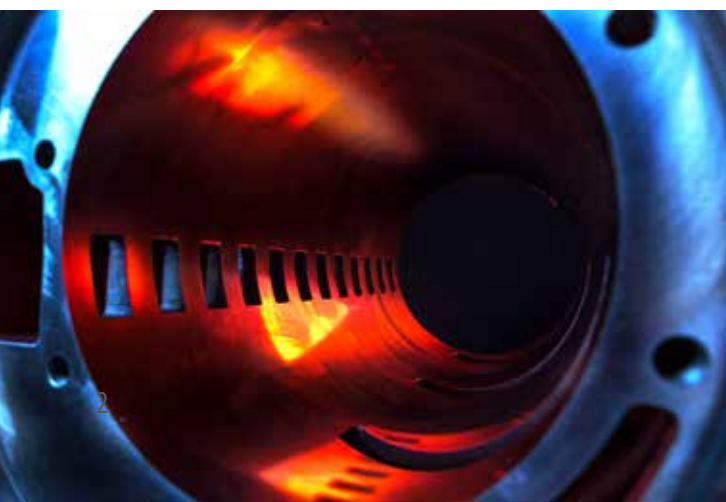
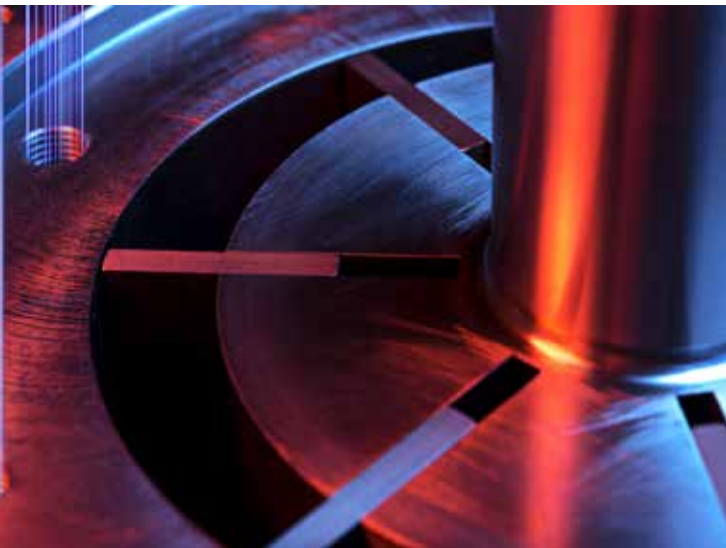

MATTEI
VALUE
PROPOSITION





MATTEI'S EXCEPTIONAL PERFORMANCE IS THE SIMPLICITY OF THE ROTARY VANE PRINCIPLE:

- Quiet and vibration free
- Pure rotary motion delivers pulse free gas
- Continuous operation 24/7
- Three stage oil separation for high quality gas
- Only one rotating part ensures long reliable life
- Intake modulation (servo control) only compress to the gas demand
- Direct drive means NO BELTS AND PULLEYS

SAFETY / RELIABILITY

The integrated design, direct coupling, low rotational speed and the limited number of moving parts ensure Mattei's rotary vane gas compressors remain safer, more durable and more reliable over time.

PRINCIPAL COMPONENTS

Rotor, blades, stator, end covers are manufactured from high quality cast iron. This means:

- No replacement required
- Totally reliable operation
- Long gas end life
- Improved efficiency



GAS COMPRESSORS

Rotary vane technology

GAS COMPRESSORS

Mattei's rotary vane Gas Compressors are designed to compress sweet, sour and bio gases.

The range covers 4kW up to 200kW available as a stand-alone gas end for local packaging or as customer specification gas compressor packages.

All versions come complete with automatic flow control at a constant delivery pressure, integrated or remote cooler and threaded or flanged gas intake facility.

The compressors are compact and easy to install, offering reliable operation and constant performance throughout time.

MAIN FEATURES	
Compression technology	Rotary Vane
Output	0% to 100%
Drive system	Direct coupled with elastic element
Cooling	Air/water – Integrated or remote panel cooler
Temperature protection	Thermistor
Controller	Fully customisable remote PLC control Maestro XS
Pressure Control	Servo with modulation - Pressure sensor - External signal Reference
Pressure protection	Safety valve
Operating ambient range	5C to + 45C (23F to + 113F)
Inlet pressure range	0 to 650mbar (0 to 8.7psi)
Acceptable gases	Sweet Gas
	Sour Gas
	Bio Gas
Maximum allowable free moisture	None
Maximum allowable H ₂ S	800ppm
Lubricant	Mattei V-Life Gas
Laws and conformity	2006/42/EC – Machinery directive
	92/27/CW PED - directive on pressure equipment
	94/9/CE – ATEX - Systems intended for use in potentially explosive atmospheres
Optional Feature	Active Zener Barrier



GAS RANGE

Rated power	4 to 200 kW
F.A.D.	0,4 to 35,3 m ³ /min
Working pressures	7/10/13 bar

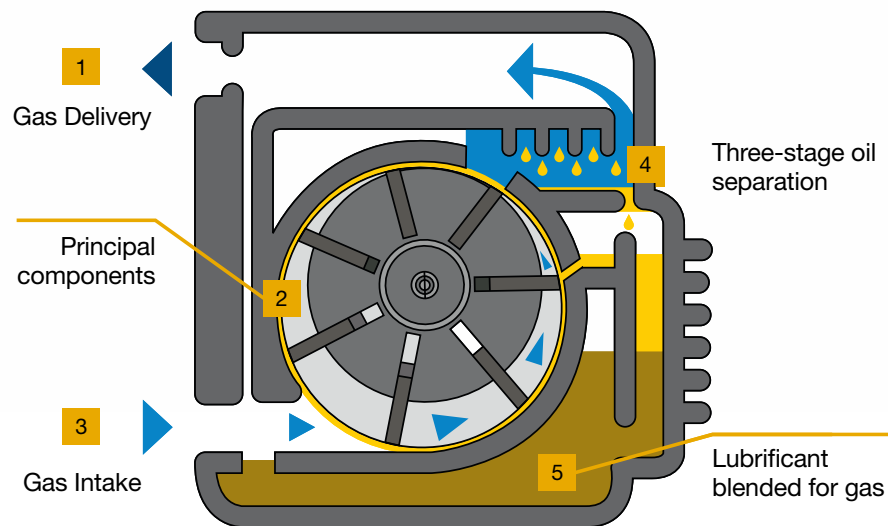

MATTEI GAS COMPRESSORS' BENEFITS

- Full Atex packages
- Bespoke designs to suit application
- Fully integrated gas ends
- Sour gas compatible
- No yellow metals
- Whisper quiet operation
- 100% duty 24/7
- No fall off in gas quality
- Direct drive
- External pressure adjustment

GAS COMPRESSORS

Rotary vane technology

REFERENCES

MICROTURBINE GENERATORS



Mattei GC 111 Gas Compressor and 50 HP motor to compress Methane gas to drive a Capstone Micro Turbine to generate electricity used at the site.



Mattei GC 86 gas end and 15 HP motor installed in a beer brewery to compress brewery waste methane gas to drive a Capstone Micro Turbine to generate electricity used at the site.



Installation of 5 Mattei 55 kW gas variable speed compressors with a pressure of 8 bar which can compress up to 9,000 litre a minute of biogas containing up to 300 ppm of hydrogen sulphide, in accordance with the microturbine specifications.

Mattei V-Life GAS

Mattei V-life **GAS** is a synthetic lubricant specifically formulated for Mattei rotary vane gas compressors, with a very high H₂S ppm tolerance. This lubricant is the correct choice for both sweet and sour gas compression.



FEATURE & BENEFITS

- 4.000 hours service life
- Prevention of acidity, sludge and deposit formation
- Excellent coolant properties
- Excellent demulsibility
- Good oxidative stability

GAS ENGINE BACK UP GENERATION



Power installation which uses 22 Mattei ERG 4 kW gas compressors feeding gas into large gas engines for electric generation.

VAPOR RECOVERY UNIT



Vapor Recovery Unit (VRU) which uses a Mattei GC 86 gas compressor and a 20HP motor to compress low pressure Methane Vapor from crude oil tanks and wellheads to higher pressure Methane gas which is then used as a fuel at each site. There are over 100 of these units operating in the Southwest United States.

BIO GAS SCRUBBING



55 kW AG gas compressors used in an installation for an ammonia-based system for removal of CO² in Biogas.

DEFLARING



Billions of cubic meters of natural gas is flared annually at oil production sites around the globe. Flaring gas wastes a valuable energy resource that could be used to support economic growth and progress. It also contributes to climate change by releasing millions of tons of CO² to the atmosphere.

The World Bank's "Zero Routine Flaring by 2030" initiative has been endorsed by a multitude of top governments and oil companies. Mattei's Rotary Vane Gas Compressors are perfectly suited to eliminate those applications where flare gasses are currently being burnt. The capturing and pressurisation of these gasses allows the end user to then decide how to recycle them, either for local power generation, or to be reintroduced at a low pressure point of the process line.



ITALY - ING. ENEA MATTEI SpA
Strada Padana Superiore, 307
20090 VIMODRONE (MI)
Tel + 39 02253051 - Fax +39 0225305243
E-mail: info@mattei.it

www.matteigroup.com



UNI EN ISO 9001:2008



FRANCE
MATTEI COMPRESSEURS Sarl
Phone +33 535 542 205 - Fax +33 972 316 833
E-MAIL: infos@mattei.fr - www.mattei.fr

GERMANY
MATTEI KOMPRESSOREN DEUTSCHLAND GmbH
Phone +49 7151 5002560 - Fax +49 7151 5002565
E-MAIL: info@mattei-kompressoren.de - www.mattei-kompressoren.de

GREAT BRITAIN
MATTEI COMPRESSORS Ltd
Phone +44 (0)1789 450577 - Fax +44 (0)1789 450698
E-MAIL: info@mattei.co.uk - www.mattei.co.uk

U.S.A.
MATTEI COMPRESSORS Inc
Phone +1 410 5217020 - Fax +1 410 5217024
E-MAIL: info@matteicomp.com - www.matteicomp.com

RUSSIAN FEDERATION
ING. ENEA MATTEI SpA
Phone +7 499 1124877
E-MAIL: mattei-rus@mail.ru

SPAIN
ING. ENEA MATTEI SpA
Phone +34 93 435 03 94 - Fax +34 93 455 26 76
E-MAIL: info@mattei.it

PEOPLE'S REPUBLIC OF CHINA
Mattei (SuZhou) Air Compressors Manufacturing Co., Ltd.
WFOE by Ing. Enea Mattei S.p.A. - Italy
Phone: +86 512 66679986 - Fax: +86 512 66679989
E-MAIL: info@matteisuzhou.cn - www.matteisuzhou.com